



ELS 系列

- 额定负载电流分为25A, 50A, 负载电压48-530 VAC
- 针对大功率工业负载的SCR 输出
- 采用DBC 基板技术
- 过零触发或随机触发型可选
- 改进的 SEMS (螺丝垫圈组合式) 紧固件
- 外壳增加防螺丝垫片旋转的设计
- 直流控制
- 带LED 输入状态指示灯
- 带IP20 保护盖
- EMC符合等级 3
- 电压尖峰吸收电路可选

产品选型

输入控制电压 4-32 VDC	25A ELS4825	50A ELS4850
--------------------	-----------------------	-----------------------

命名规则

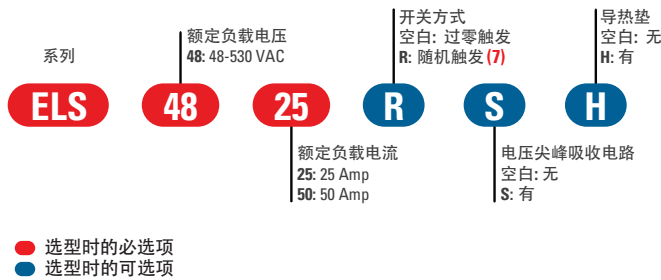

输出特性 (1)

描述	25A	50A
额定负载电压 (47-440Hz) [Vrms] (2)	48-530	48-530
瞬态峰值耐压 [Vpk]	800	800
最大断态漏电流 @ 最大额定负载电压 [mA] (3)	1.0	1.0
断态临界电压上升率 dv/dt @ 最大额定负载电压 [V/μsec]	500	500
最大负载电流 [Arms] (4)	25	50
最小负载电流 [mA]	150	150
最大浪涌电流 @ 1 个周期 [50/60] [A _{pk}]	239/250	597/625
通态峰值压降 @ 额定电流 [Vrms]	1.15	1.15
热阻 (结-基板 R _{jc}) [°C/W]	0.8	0.45
最大 I ² t 50/60Hz (1/2 周期) [A ² sec]	285/259	1770/1621
最小功率因数 @ 最大负载电流	0.5	0.5

输入特性 (1)

描述	参数
控制电压	4-32 VDC
最小开启电压 (5)	4 VDC
最大关断电压	1.0 VDC
最大反向电压	-32 VDC
典型输入电流	10 mA @ 12 VDC
输入电路类型	恒流型
最大开启动作时间 [msec] (6)	1/2 周期
最大关断动作时间 [msec]	1/2 周期

常规特性 ⁽¹⁾

描述	参数
绝缘强度, 输入/输出/基板 (50/60Hz)	4000 Vrms
最小绝缘电阻 (@ 500 VDC)	10 ⁹ Ohm
最大输入/输出电容	10 pF
使用温度	-40 to 80 °C
存储温度	-40 to 125 °C
重量 (典型值)	2.8 oz (81.5 g)
外壳材料	UL94 V-0
基板材料	铝
输入端子螺丝扭矩 (in-lbs/Nm)	13-15/1.5-1.7
输出端子螺丝扭矩 (in-lbs/Nm)	18-20/2.0-2.2
SSR 固定螺丝扭矩 (in-lbs/Nm)	18-20/2.0-2.2
最大工作湿度	85% non-condensing
LED 输入状态指示灯	绿色

原理框图

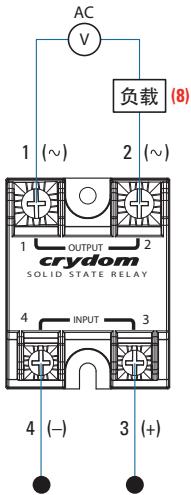

推荐型号		
端子	线大小 (单芯 / 多股)	线拔出强度 (lbs)[N]
输入	24 AWG (0.2 mm ²) / 0.2 [最小]	10 [44.5]
	2 x 12 AWG (3.3 mm ²) / 3.3 [最大]	90 [400]
输出	20 AWG (0.5 mm ²) / 0.518 [最小]	30 [133]
	2 x 10 AWG (5.3 mm ²) / 5.3	110 [490]
	2 x 8 AWG (8.4 mm ²) / 8.4 [最大]	90 [400]

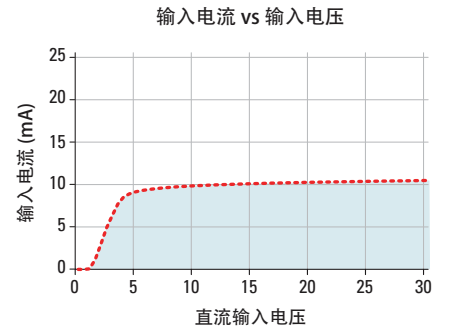

等效原理框图

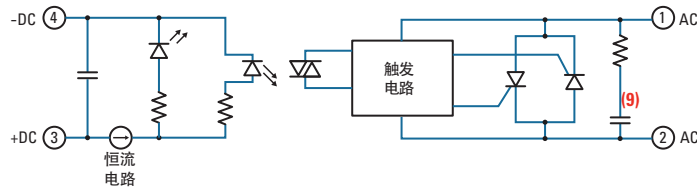

外形尺寸 (1)

公差: ±0.02 in / 0.5 mm
单位: 英寸[毫米]

螺丝端子

螺丝端子 IP20

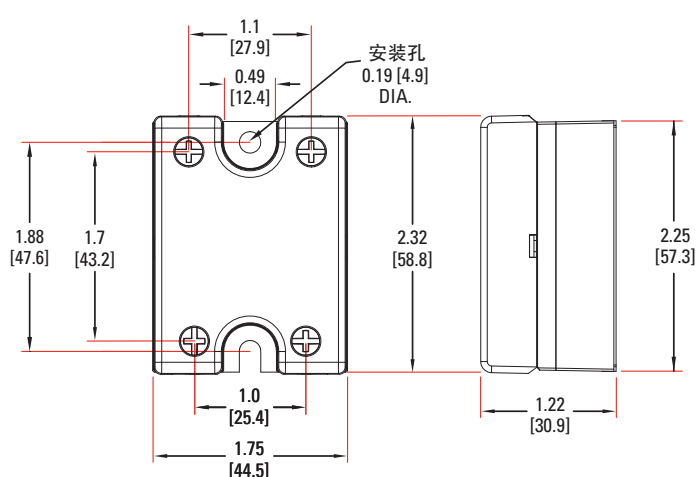
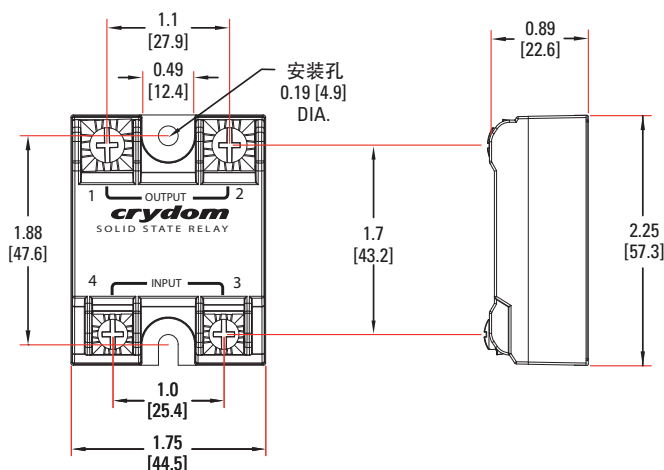

备注

- (1) 未特殊注明,所列参数均为25°条件下典型值.
- (2) 带“S”产品,工作电压的频率是47-63Hz.
- (3) 带“S”产品,最大断态漏电流是10mA.
- (4) 需加装散热器,参考产品降额曲线.
- (5) 工作在-20到-40°C时,最小控制电压需增加1V.
- (6) 随机型产品最大开启动作时间是0.1ms.
- (7) 容性负载使用过零触发型.
- (8) 负载可以选择连接在SSR的输出端1或2.
- (9) 可选择的电压尖峰吸收电路.

对于额外信息或具体问题,请联系 Crydom 技术支持.

浪涌电流

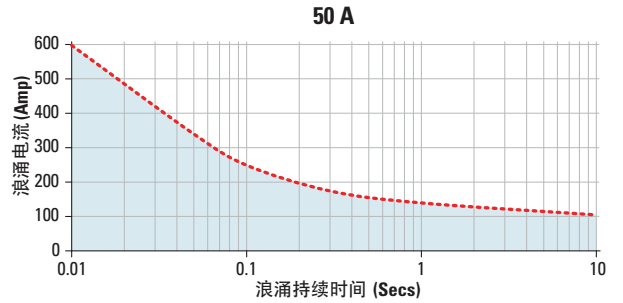
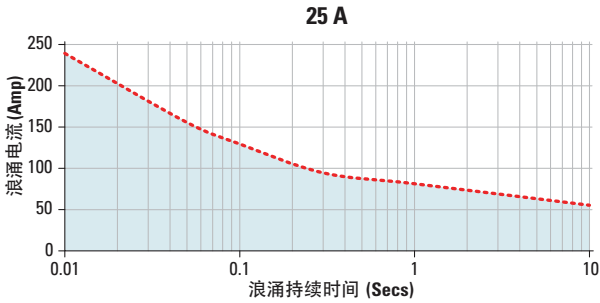

非重复峰值浪涌电流在 Tj 最初 40 °C

降额曲线

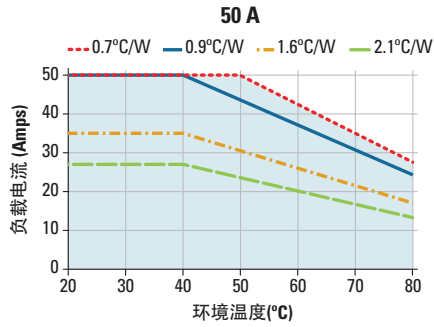
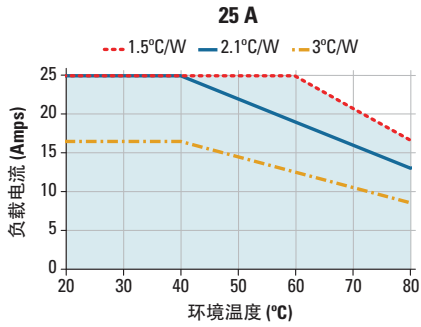

产品认证

设计是基于IEC62314的要求
 IEC 61000-4-2 : 静电放电 – Level 3
 IEC 61000-4-4 : 电快速瞬变 – Level 3
 IEC 61000-4-5 : 电涌 – Level 3



! DANGER / PELIGRO / DANGER /GEFAHR / PERICOLO / 危险

<p>HAZARD OF ELECTRIC SHOCK, EXPLOSION, OR ARC FLASH.</p> <ul style="list-style-type: none"> Disconnect all power before installing or working with this equipment. Verify all connections and replace all covers before turning on power. <p>Failure to follow these instructions will result in death or serious injury.</p>	<p>RIESGO DE DESCARGA ELECTRICA O EXPLOSION.</p> <ul style="list-style-type: none"> Desconectar todos los suministros de energia a este equipo antes de trabajar con este equipo. Verificar todas las conexiones y colocar todas las tapas antes de energizar el equipo. <p>El incumplimiento de estas instrucciones puede provocar la muerte o lesiones serias.</p>	<p>RISQUE DE DESCARGE ELECTRIQUE OU EXPLOSION</p> <ul style="list-style-type: none"> Eteindre toutes les sources d'énergie de cet appareil avant de travailler dessus de cet appareil Vérifier tous connections, et remettre tous couverts en place avant de mettre sous <p>De non-suivi de ces instructions provoquera la mort ou des lésions sérieuses.</p>	<p>GEFAHR EINES ELEKTRISCHEN SCHLAGES ODER EINER EXPLOSION.</p> <ul style="list-style-type: none"> Stellen Sie jeglichen Strom ab, der dieses Gerät versorgt, bevor Sie an dem Gerät Arbeiten durchführen Vor dem Drehen auf Energie alle Anschlüsse überprüfen und alle Abdeckungen ersetzen. <p>Unterlassung dieser Anweisungen können zum Tode oder zu schweren Verletzungen führen.</p>	<p>RISCHIO DI SCOSSA ELETTRICA O DELL'ESPLOSIONE.</p> <ul style="list-style-type: none"> Spenda tutta l'alimentazione e che fornisce questa apparecchiatura prima del lavorare a questa apparecchiatura Verificare tutti i collegamenti e sostituire tutte le coperture prima della rotazione sull'alimentazione <p>L'omissione di seguire queste istruzioni provocherà la morte o di lesioni serie</p>	<p>存在电击、爆炸或电弧闪烁危险</p> <ul style="list-style-type: none"> 在操作此设备之前请先关闭电源。 <p>若不遵守这些说明，可能会导致严重的人身伤害甚至死亡。</p>
--	--	---	---	---	---

! WARNING / AVERTISSEMENT / WARNUNG /ADVERTENCIA / AVVERTENZA / 警告

<p>RISK OF MATERIAL DAMAGE AND HOT ENCLOSURE</p> <ul style="list-style-type: none"> The product's side panels may be hot, allow the product to cool before touching. Follow proper mounting instructions including torque values. Do not allow liquids or foreign objects to enter this product. <p>Failure to follow these instructions can result in serious injury, or equipment damage.</p>	<p>RISQUE DE DOMMAGE MATERIEL ET DE SURCHAUFFE DU BOITIER</p> <ul style="list-style-type: none"> Les panneaux latéraux du produit peuvent être chauds. Laissez le produit refroidir avant de le toucher. Respecter les consignes de montage, et notamment les couples de serrage. Ne pas laisser pénétrer de liquide ni de corps étrangers à l'intérieur du produit. <p>Le non-respect de cette directive peut entraîner, des lésions corporelles graves ou des dommages matériels.</p>	<p>GEFAHR VON MATERIALSCHÄDEN UND GEHÄUSEERHITZUNG</p> <ul style="list-style-type: none"> Die Seitenwände können heiß sein. Lassen Sie das Produkt abkühlen, bevor Sie es berühren. Beachten Sie die Montageanweisungen, Führen Sie keine Flüssigkeiten oder Fremdkörper in das Produkt ein. <p>Die Nichtbeachtung dieser Anweisung kann Körperverletzung oder Materialschäden zur Folge haben.</p>
<p>RIESGO DE DAÑOS MATERIALES Y DE SOBRECIENTAMIENTO DE LA UNIDAD</p> <ul style="list-style-type: none"> Los paneles laterales del producto pueden estar calientes. Esperar que el producto se enfríe antes de tocarlo. Respetar las instrucciones de montaje, y en particular los pares de apretado. No dejar que penetren líquidos o cuerpos extraños en el producto. <p>Si no se respetan estas precauciones pueden producirse graves lesiones, daños materiales.</p>	<p>RISCHIO DI DANNI MATERIALI E D'INVOLUCRO CALDO</p> <ul style="list-style-type: none"> I pannelli laterali dell'apparecchio possono scottare; lasciar quindi raffreddare il prodotto prima di toccarlo. Seguire le istruzioni di montaggio corrette. Non far entrare liquidi o oggetti estranei in questo apparecchio. <p>La mancata osservanza di questa precauzione può causare gravi rischi per l'incolumità personale o danni alle apparecchiature.</p>	<p>材料损坏和高温外壳的危险性</p> <ul style="list-style-type: none"> 产品的一侧面板可能很热，在其冷却前请不要触碰。 遵照正确的安装说明，包括扭矩值。 请勿让液体及其他异物进入本产品。 <p>如不能正确执行这些操作说明，极有可能造成严重人体伤害或者设备的损坏。</p>

ANNEX - ENVIROMENTAL INFORMATION

The environmental information disclosed in this annex including the EIP Pollution logo are in compliance with People’s Republic of China Electronic Industry Standard SJ/T11364 – 2006, Marking for Control of Pollution Caused by Electronic Information Products.

Part Name	Toxic or hazardous Substance and Elements					
	Lead (Pb)	Mercury (Hg)	Cadmium (Cd)	Hexavalent Chromium (Cr (VI))	Polybrominated biphenyls (PBB)	Polybrominated diphenyl ethers (PBDE)
Semiconductor die	X	O	O	O	O	O
Solder	X	O	O	O	O	O

附件 - 环保信息

此附件所标示的包括电子信息产品污染图标的环保信息符合中华人民共和国电子行业标准 SJ/T11364 - 2006, 电子信息产品污染控制标识要求。

部件名称	有毒有害物质或元素					
	铅 (Pb)	汞 (Hg)	镉 (Cd)	六价铬 (Cr (VI))	多溴联苯 (PBB)	多溴二苯醚 (PBDE)
半导体芯片	X	O	O	O	O	O
焊接点	X	O	O	O	O	O

